



两片式, 法兰端, 高平台, 全流量球阀
Two pieces, Flange, ISO5211 pad direct, full bore ball valve

标准规范 STANDARD SPECIFICATION

- ★设计规范 Design: GB/T12224 GB/T12237 ASME B16.34 API608
- ★结构长度 Face to Face: GB/T12221 ASME 16.10
- ★法兰接端 End Flange: GB/T9113.1 ASME 16.5
- ★检验与测试 Inspection and Testing: GB/T13927, API598 API6D

设计特性 DESIGN FEATURES

- ★采用ISO 5211直接安装执行器的平台设计
Built-in ISO 5211 Direct Mounting Pad and Square Stem for Easy Automation
- ★阀杆与阀体之间带防静电装置 Anti Static Devices for Ball-stem-body
- ★阀杆防爆出设计 Blow-out Proof Stem
- ★阀体防火设计 Fire Protection Design

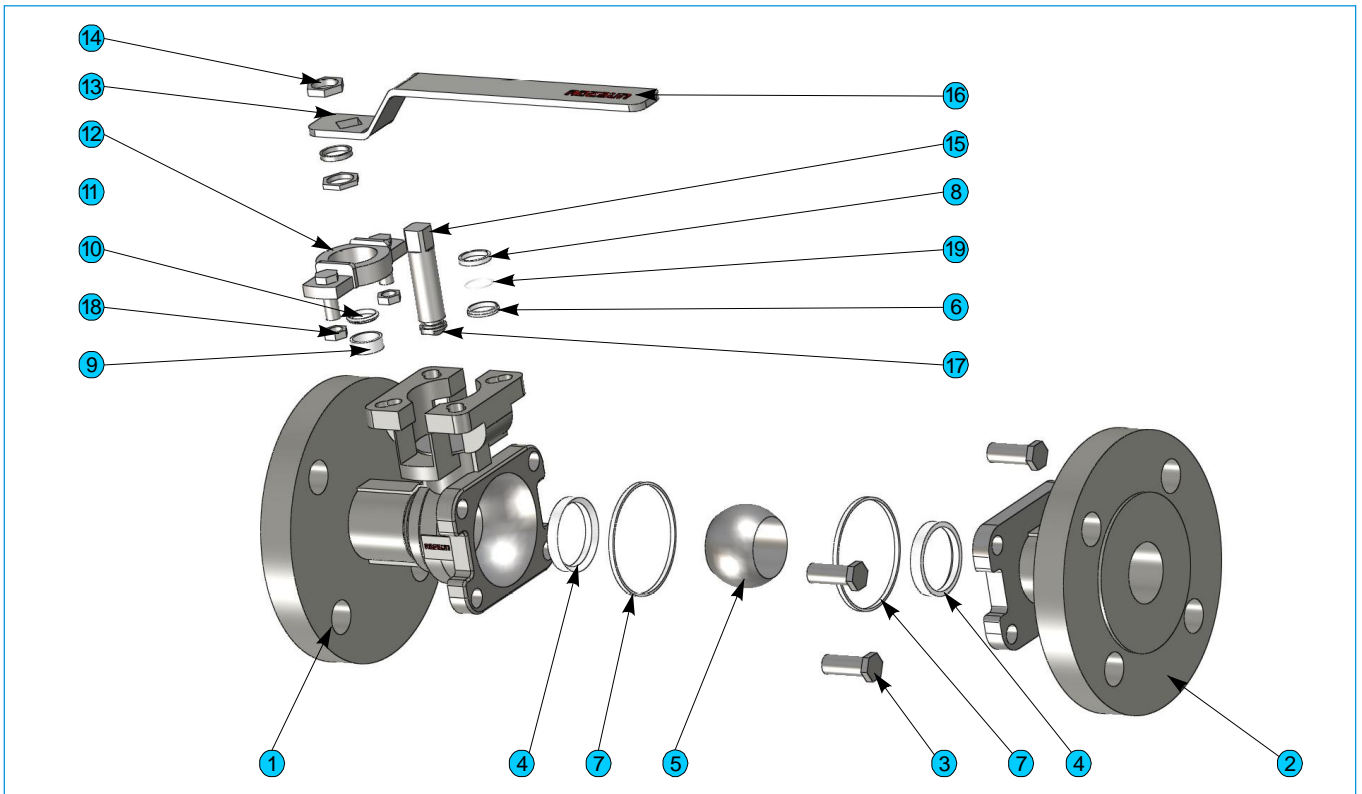

序号 NO.	零件名称 PART NAME	材质 MATERIAL			序号 NO.	零件名称 PART NAME	材质 MATERIAL	
1	阀体 BODY	CF8M	CF8	WCB	11	牛腩 BONNET	CF8	
2	阀盖 CAP	CF8M	CF8	WCB	12	牛腩挡片 BONNET STOPPER	CF8	
3	固定螺丝 HEX BOLT	A193-B8	A193-B7		13	把手 HANDLE	CF8	
4	球垫 SEAT	PTFE			14	把手螺帽 HANDLE NUT	A194-8	
5	钢球 BALL	SUS316	SUS304		15	中轴 STEM	CF8M	CF8
6	小薄片 (L)	PTFE			16	把手胶套 COVER	PLASTIC	
7	大薄片 GASKET	PTFE			17	静电珠 ANTI STATIC	CF8M	CF8
8	中口 STEM PACKING	PTFE			18	牛腩螺丝+螺母 BONNET BOLT AND NUT	CF8	
9	环套 GLAND	CF8						
10	笠华司 DISC SPRING	SUS301			19	O型圈 O-RING	FKM	

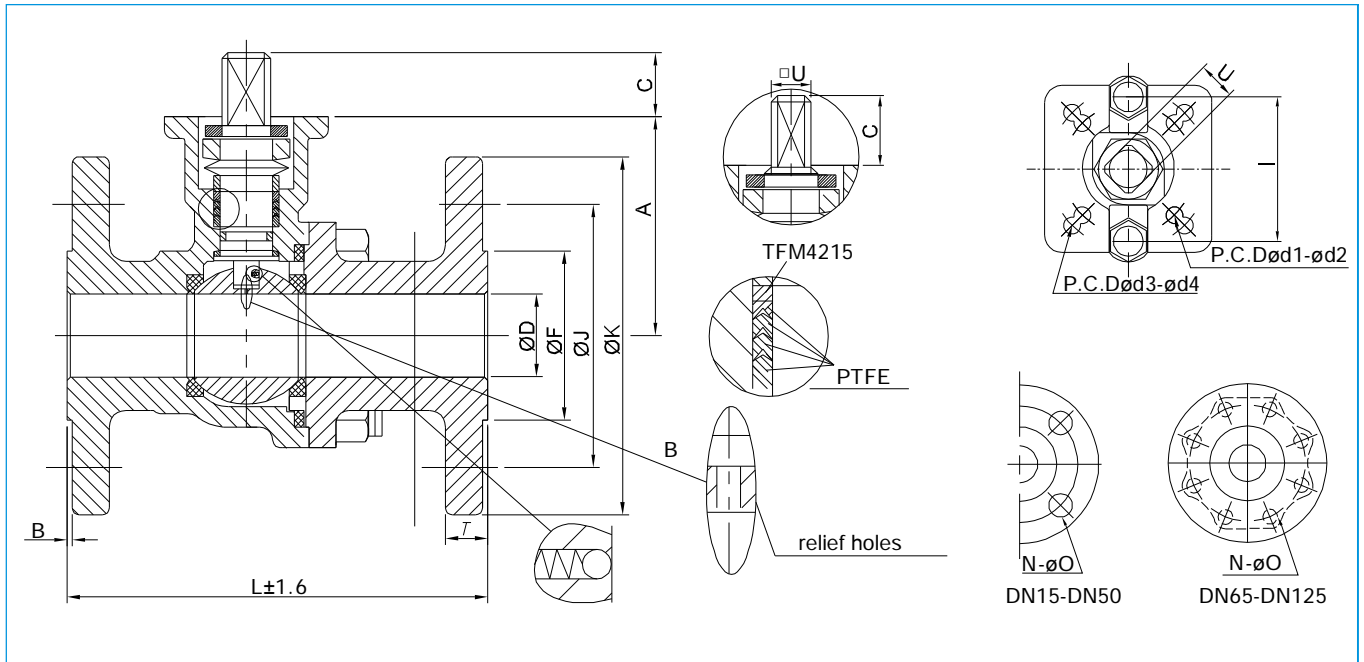

国标法兰 (PN16-PN40) 外形尺寸 GB Flange (PN16-PN40) Dimensions

尺寸	PN	ØD	L	ØF	ØJ	K	T	C	A	ISO 5211	N	Øh	E	B
DN15	16/40	15	130	46	65	95	14	9	49	F03/F05	4	14	97	29
DN20	16/40	20	130	56	75	105	16	9	54	F03/F05	4	14	97	29
DN25	16/40	25	140	65	85	115	16	10	58.5	F04/F05	4	14	142	49.5
DN32	16/40	32	165	76	100	140	18	10	71	F04/F05	4	18	142	38
DN40	16/40	38	165	84	110	150	18	14	77.5	F05/F07	4	18	190	39.2
DN50	16/40	50	203	99	125	165	20	14	85.8	F05/F07	4	18	190	40.2
							22							
DN65	16/40	64	222	118	145	185	20	17	113.8	F07/F10	4	18	350	59
							22							
DN80	16/40	76	241	132	160	200	20	17	122	F07/F10	8	18	350	60
							24							
DN100	16/40	100	305	156	180	220	22	17	138	F07/F10	8	22	350	60
					190	235	24							
DN125	16/40	125	356	184	210	250	22	22	164	F10/F12	8	18	-	-
					220	270	26					26		
DN150	16/40	150	394	211	240	285	24	27	204	F10/F12	8	22	-	-
					250	300	28					26		
DN200	16/40	200	457	266	295	340	24	27	255.5	F10/F12	12	22	-	-
				284	320	375	34					30		

美标 150LB 外形尺寸 ANSI 150 Dimensions

尺寸	PN	øD	L	øF	øJ	K	T	C	A	ISO 5211	N	øh	E	B
DN15	150LB	15	108	34.9	60.3	88.9	9.6	8	49	F03/F05	4	15.9	97	29
DN20	150LB	20	117	42.9	69.8	98.4	10.5	8	54	F03/F05	4	15.9	97	29
DN25	150LB	25	127	50.8	79.4	107.9	11.2	11	64.5	F04/F05	4	15.9	142	49.5
DN32	150LB	32	140	63.5	88.9	117.5	12.8	11	71	F04/F05	4	15.9	142	38
DN40	150LB	38	165	73	98.4	127	14.3	13.5	77.5	F05/F07	4	15.9	190	39.2
DN50	150LB	50	178	92.1	120.6	152.4	15.9	13.5	85.8	F05/F07	4	19	190	40.2
DN65	150LB	64	190	104.8	139.7	177.8	17.5	17.5	113.8	F07/F10	4	19	350	59
DN80	150LB	76	203	127	152.4	190.5	19.1	17.5	122	F07/F10	4	19	350	60
DN100	150LB	100	229	157.2	190.5	228.6	22.3	17.5	138	F07/F10	8	19	350	60
DN125	150LB	125	356	185.7	215.9	254	23.8	22	164	F10/F12	8	22.2	-	-
DN150	150LB	150	394	215.9	241.3	279.4	25.4	27	204	F10/F12	8	22.2	-	-
DN200	150LB	200	457	269.9	298.4	342.9	28.6	27	255.5	F10/F12	8	22.2	-	-

CV

SIZE	0°	10°	20°	30°	40°	50°	60°	70°	80°	90°
DN15	0	0.05	2.35	6.00	10.36	15.17	20.29	25.62	31.07	36.57
DN20	0	0.10	4.39	11.18	19.30	28.27	37.81	47.73	57.88	68.14
DN25	0	0.16	7.04	17.93	30.96	45.36	60.67	76.58	92.87	109.32
DN32	0	0.28	11.91	30.32	52.34	76.66	102.54	129.44	156.97	184.77
DN40	0	0.45	18.93	48.18	83.17	121.83	162.96	205.71	249.45	293.63
DN50	0	0.75	31.33	79.75	137.68	201.67	269.73	340.50	412.90	486.03
DN65	0	1.31	54.36	138.37	238.87	349.89	467.98	590.75	716.37	843.24
DN80	0	1.98	82.31	209.51	361.66	529.76	708.55	894.44	1084.63	1276.72
DN100	0	3.19	132.51	337.27	582.22	852.82	1140.66	1439.90	1746.08	2055.31
DN125	0	5.13	212.99	542.11	935.82	1370.77	1833.41	2314.39	2806.52	3303.55
DN150	0	7.62	316.34	805.15	1389.89	2035.88	2723.01	3437.36	4168.28	4906.47
DN200	0	14.03	582.61	1482.88	2559.81	3749.55	5015.06	6330.70	7676.86	9036.41

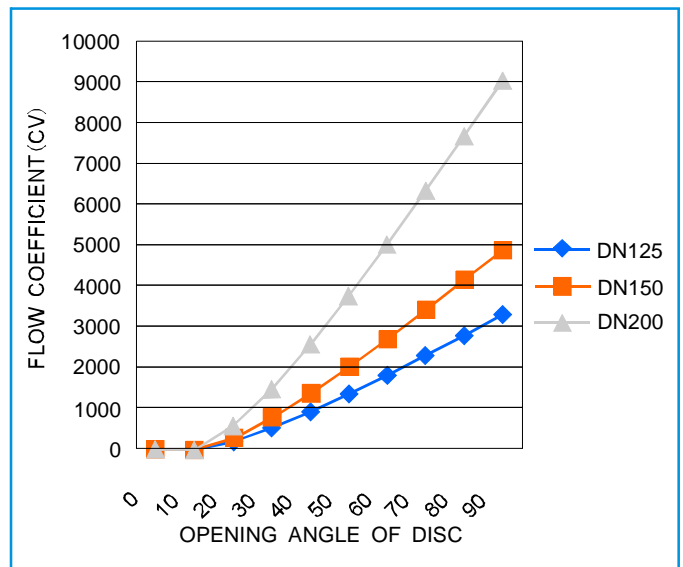
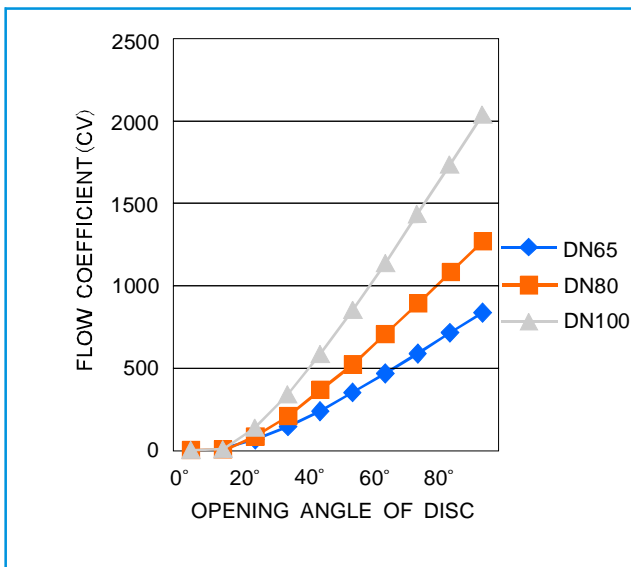
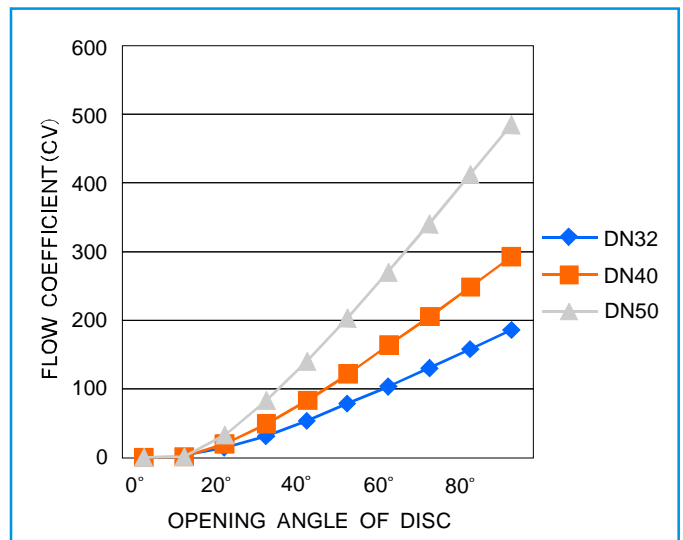
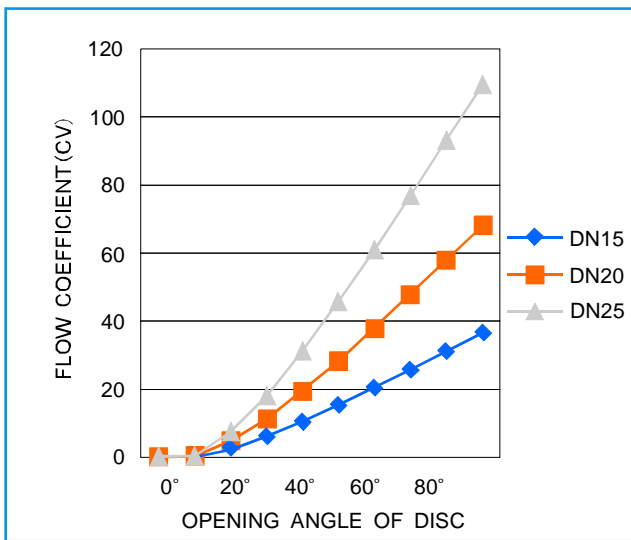

扭矩 (不含安全系数) TORQUES (UN INCLUDING SAFETY FACTOR)

SIZE 尺寸	DN15	DN20	DN25	DN32	DN40	DN50	DN65	DN80	DN100	DN125	DN150	DN200
TORQUE 扭矩(Nm)	5	8	10	16	23	30	64	103	129	323	380	487

温度压力对照表 TEMPERATURE AND PRESSURE CURVE

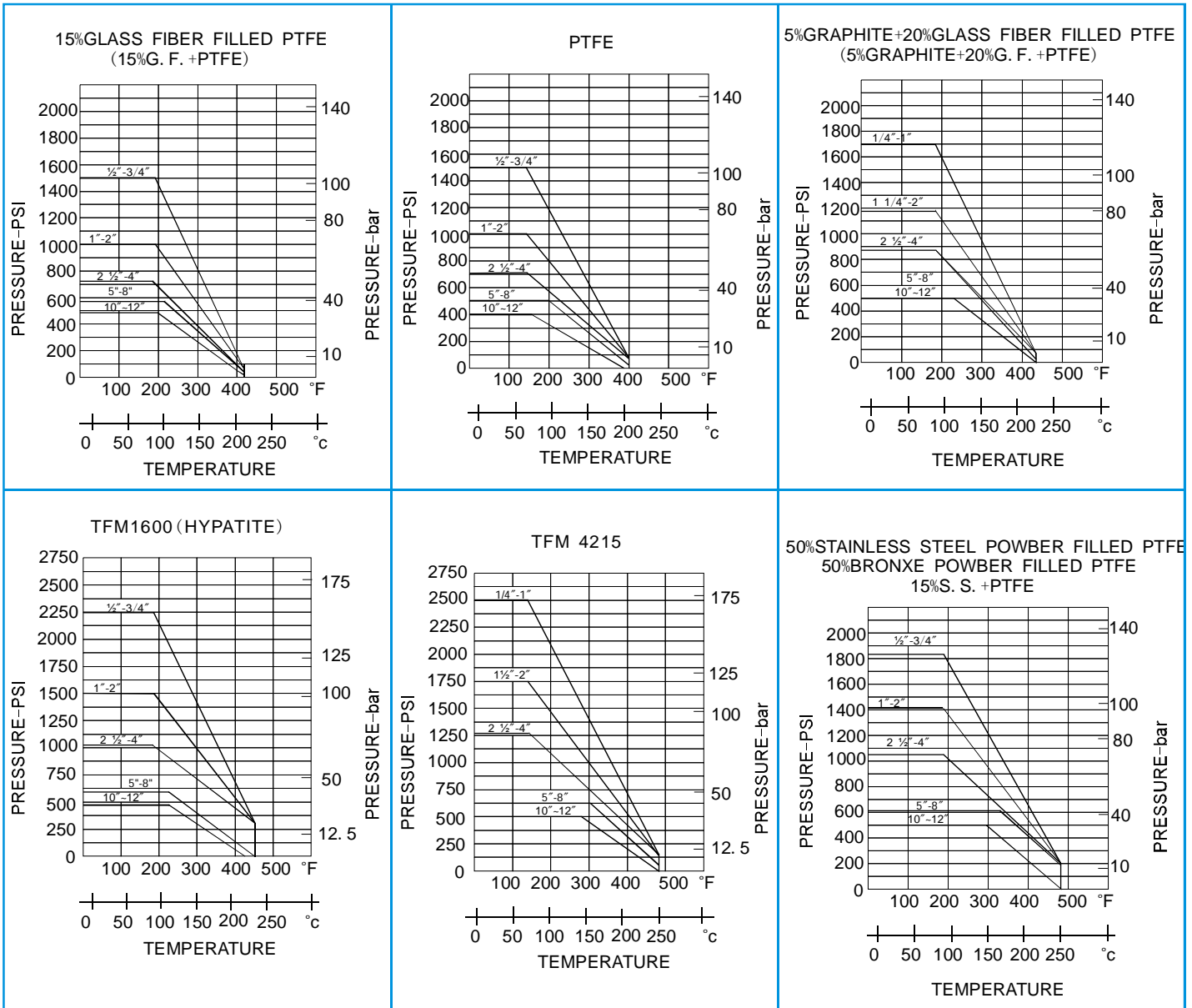

Art. 340系列法兰球阀选型表

Art. 340 series product ordering matrix

340	D	A	010	G	-	HABL	V型球选型
系列号 series	驱动形式 Actuation Type H-手动手柄 manual handle D-气动双动 double acting S-气动单动 spring return E-电动开关型 on/off M-电动调节型 modulating W-光杆 Bare Shaft	阀体材质 body material A-CF8M B-CF8 C-WCB	口径 size 010-DN10 3/8" 015-DN15 1/2" 020-DN20 3/4" 025-DN25 1" 032-DN32 1-1/4" 040-DN40 1-1/2" 050-DN50 2" 065-DN65 2-1/2" 080-DN80 3"	连接形式 connection G-GB Flange (PN16) 1-ANSI 150 2-ANSI 300 3-GB Flange (PN40) 4-DIN Flange (PN16) 5-DIN Flange (PN40)		特别代码 special code 手动-空白 handle-Blank 光杆-空白 Bare Shaft-Blank	V10° V15° V30° V45° V60° V90°
<p>备注：如有其他要求请详询。 Notes: If you have other requirements on request, please contact sales department.</p>							

配 **ADESUN** 电动执行器 / with **ADESUN** electrical actuator

Art: 340EB*G - *** - PN10/PN16**
 口径 特别代码

开关型 / On-off-model

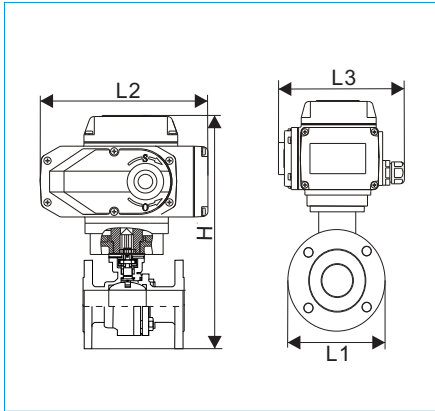

型号 CODE	340EB015G +HBT	340EB20G +HBT	340EB025G +HBT	340EB032G +HBT	340EB040G +HBT	340EB050G +HBT	340EB065G +HBT	340EB080G +HBT	340EB100G +HBT	340EB125G +HBT	340EB150G +HBT
DN	15	20	25	32	40	50	65	80	100	125	150
PN	10/16	10/16	10/16	10/16	10/16	10/16	10/16	10/16	10/16	10/16	10/16
ACT	AEA-02	AEA-02	AEA-05	AEA-05	AEA-05	AEA-05	AEA-10	AEA-20	AEA-20	AEA-40	AEA-60
H (mm)	244	254	279	306	319	335	404	459	510	504	591
L1 (mm)	95	105	115	140	150	165	185	200	220	250	285
L2 (mm)	72	72	160	160	160	160	196	255	255	255	255
L3 (mm)	75	75	137	137	137	137	145	182	182	182	182

有源触点 / Active contact

Y											
---	--	--	--	--	--	--	--	--	--	--	--

无源触点 / Dry contact

型号 CODE	340EB015G +HBT	340EB20G +HBT	340EB025G +HBT	340EB032G +HBT	340EB040G +HBT	340EB050G +HBT	340EB065G +HBT	340EB080G +HBT	340EB100G +HBT	340EB125G +HBT	340EB150G +HBT
Y											

24VDC

型号 CODE	340EB015G +HBT	340EB20G +HBT	340EB025G +HBT	340EB032G +HBT	340EB040G +HBT	340EB050G +HBT	340EB065G +HBT	340EB080G +HBT	340EB100G +HBT	340EB125G +HBT	340EB150G +HBT
Y											

380VAC

型号 CODE	340EB015G +HBT	340EB20G +HBT	340EB025G +HBT	340EB032G +HBT	340EB040G +HBT	340EB050G +HBT	340EB065G +HBT	340EB080G +HBT	340EB100G +HBT	340EB125G +HBT	340EB150G +HBT
ACT	AEA-05H	AEA-05H	AEA-05H	AEA-05H	AEA-05H	AEA-05H	AEA-10H	AEA-20H	AEA-20H	AEA-40H	AEA-60H
H (mm)	259	270	279	306	319	335	404	459	510	504	591
L1 (mm)	95	105	115	140	150	165	185	200	220	250	285
L2 (mm)	160	160	160	160	160	160	196	255	255	255	255
L3 (mm)	137	137	137	137	137	137	145	182	182	182	182

Y											
---	--	--	--	--	--	--	--	--	--	--	--

更大口径另询
More size on request

配 **ADESUN** 电动执行器 / with **ADESUN** electrical actuator

Art: 340MB*G - *** - PN10/PN16**
 口径 特别代码

调节型 / Modulating model

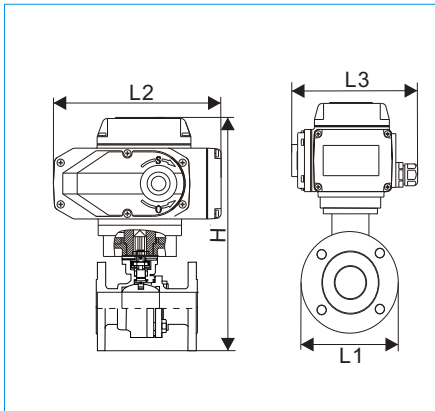

型号 CODE	340EB015G +HBT	340EB20G +HBT	340EB025G +HBT	340EB032G +HBT	340EB040G +HBT	340EB050G +HBT	340EB065G +HBT	340EB080G +HBT	340EB100G +HBT	340EB125G +HBT	340EB150G +HBT
DN	15	20	25	32	40	50	65	80	100	125	150
PN	10/16	10/16	10/16	10/16	10/16	10/16	10/16	10/16	10/16	10/16	10/16
ACT	AEA-05E	AEA-05E	AEA-05E	AEA-05E	AEA-05E	AEA-05E	AEA-10E	AEA-20E	AEA-20E	AEA-40E	AEA-60E
H (mm)	260	270	279	306	319	335	404	459	510	504	591
L1 (mm)	95	105	115	140	150	165	185	200	220	250	285
L2 (mm)	160	160	160	160	160	160	196	255	255	255	255
L3 (mm)	137	137	137	137	137	137	145	182	182	182	182

Y											
---	--	--	--	--	--	--	--	--	--	--	--

更大口径另询
More size on request